

# HAM TIPS



A PUBLICATION OF THE TUBE DEPARTMENT · RCA · HARRISON, N. J.

Volume X, No. 3

Fall, 1950

## Design and Application of High-Pass Filters

By

Mack Seybold, W2RYI\*

Although filter theory is apt to be appreciated by the advanced amateur, the average ham prefers to avoid the subject because of the mathematics involved. If you would like to build a high-pass filter for your TV set to preserve peace in the family or to assist a neighbor in obtaining adequate low-frequency rejection in his receiver, this is the dope you have been waiting for. Easy-to-build filters are fully described.

**T**HE causes of interference to television reception encountered when an amateur station is transmitting can be divided into three classifications: harmonic radiation from the transmitter, generation and radiation of harmonics by external non-linear devices\*\* excited by the amateur signal, and incomplete rejection of the amateur fundamental signal by the television receiver. If an amateur transmitter has been TVI-proofed, and if the external producers of detrimental harmonic radiation have been eliminated, then most of the remaining interference difficulties can be attributed to inadequate receiver rejection.

Television receivers vary in ability to reject low-frequency signals. Some have a tuned rf stage and a built-in, high-pass filter. In many installations, in the vicinity of amateurs, these require no additional filtering. Some receivers have only a choke input to the rf tube, and no provision for the rejection of strong signals.

If a television receiver does not reject amateur signals from the 80- and 160-meter amateur bands, interference may be produced

\*RCA Tube Dept., Harrison, N. J.

\*\*Rectifiers, either oxide or thermionic, connected to electrical conductors. Also pipe junctions, air-duct and drain-pipe joints, telephone buttons, corroded ground clamps, radio receivers, etc.

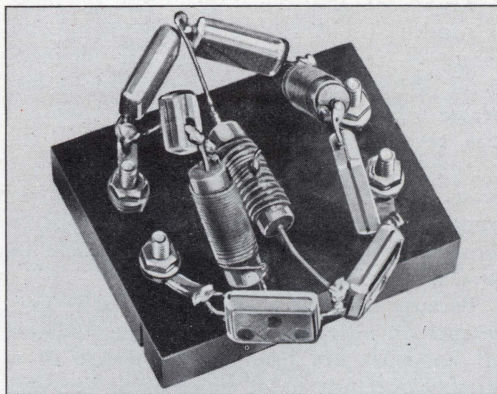

Fig. 1. A two-section, series-derived filter which can be connected to the antenna terminals on the TV receiver.

in the video amplifier. Signals from the 10- and 11-meter bands can produce interference in the if amplifier, and strong signals from practically all amateur bands can produce interference in the "front end" of the television receiver. Most of the difficulties arise in the front end, and the major phenomena involved are blocking, rectification, and heterodyning.

Blocking occurs when a strong extraneous signal reduces the gain of the receiver by taking over the avc action or by driving the control grid of an amplifier tube to a positive potential, thereby producing grid current which biases the stage to a potential at which no amplification can take place.

Rectification occurs in the grid-cathode circuit of an rf amplifier when an extraneous signal swings the grid beyond the linear portion of the tube's characteristic curve. Harmonics are then produced by this action, and they are exact multiples of the frequency of

the extraneous signal. When one of these harmonics falls in a television channel, a cross-hatched picture may be produced.

Heterodyning occurs when an amateur signal and a second extraneous signal enter the receiver. For instance, a 14-Mc amateur signal can heterodyne the channel-2 picture carrier at 55.25 Mc into the middle of channel 4 at 69.25 Mc so that a "lacy" mixture of the two pictures is in evidence on channel 4.

The effects of heterodyning, rectification, if interference, etc., may be encountered individually or in combinations, but all are evidence that the TV receiver has inadequate low-frequency rejection. Devices to improve rejection may be installed at the antenna terminals of the television receiver, and one of the simplest of these devices is a pair of tuned traps.

Traps are effective only if the amateur transmitter is operated in a relatively narrow range of frequencies within one amateur band. When the amateur transmitter is operated over a considerable range of frequencies, several pairs of traps can be installed, but problems of matching the television antenna to the receiver are encountered. It is sometimes difficult to get multiple traps to work without causing signal attenuation in several television channels.

Because very few amateurs operate by preference on only one frequency, and because all amateurs are licensed to operate in a number of bands, six of which occur between the frequencies 1.75 and 30 Mc, tuned traps are usually inadequate, and a more efficient device, the high-pass filter, is required for the protection of a receiver located in the vicinity of an amateur transmitter.

### Filter Requirements

A high-pass filter for a television receiver has two primary requirements. First, it should reject all signals below the lowest local television frequency. Second, it should function, at television frequencies, as a transmission line having a characteristic resistance equal to that of the television antenna feeder. A theoretically perfect high-pass filter would be capable of fulfilling these requirements; however, in actual practice, compromises must be made in "rejectability" to permit reasonable performance in the TV pass-bands.

For instance, if an attempt were made to design a high-pass filter that would reject all signals below 54 Mc and pass all signals above 55 Mc, the Q of the circuits required would be so high that it would be impossible to construct the device from available com-

ponents. Even with the best coils and capacitors, the nearest peak-attenuation frequency can be set no nearer than five per cent of the cutoff frequency. Spurious responses that occur in the vicinity of the cutoff frequency of such a filter would also cause difficulties between 50 and 60 Mc. Therefore, rejection of signals from the 6-meter amateur band, especially in a location where channel 2 is assigned, is impractical with a high-pass filter. If a 6-meter signal is to be rejected, the installation of a separate set of tuned traps is the easiest solution to the problem.

For rejecting signals from all of the amateur bands below 30 Mc, however, a high-pass filter is the most practical device that can be installed. With a 25-Mc separation between the television portions of the spectrum and the 10-meter amateur band, there is plenty of room to juggle cutoff frequencies and peak-attenuation frequencies so that optimum conditions can be met for rejecting unwanted signals and accepting all television signals from channel 2 through channel 13.

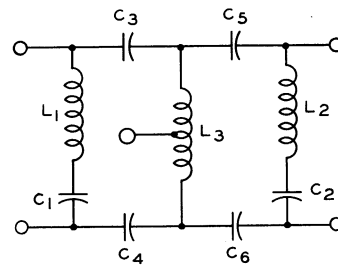

Fig 2. Two-section, series-derived, high-pass filter for a 300-ohm line (Cutoff: approx. 36 Mc).

C<sub>1</sub>, C<sub>2</sub> 15 $\mu$ f, mica capacitor,  $\pm$  10% tolerance.

C<sub>3</sub>, C<sub>4</sub>, C<sub>5</sub>, C<sub>6</sub> 20 $\mu$ f, mica capacitor  $\pm$  10% tolerance.

L<sub>1</sub>, L<sub>2</sub> 2.0 $\mu$ h, 24 turns of #28 DCC wire, coil length  $\frac{5}{8}$ " on  $\frac{1}{4}$ " diam. form. Correct inductance\* can be obtained by adjusting the turns to resonate with the associated 15- $\mu$ f capacitor at 29 Mc, before setting turns with wax or coil dope.

L<sub>3</sub> 0.66  $\mu$ h, 13 turns of #28 DCC wire, coil length  $\frac{5}{8}$ " on a  $\frac{1}{4}$ " diam. form, center tapped. Correct inductance\* can be obtained by adjusting turns to resonate at 19.8 Mc with an auxiliary 100- $\mu$ f capacitor.

\*Note: If measuring equipment or a grid-dip meter is available, inductances and resonant sections can be adjusted close to specified values. If measuring equipment is not available, however, the coil specifications should be followed closely and a reasonably good filter can be built.

### Constructional Details

The circuit and constructional data are given in Fig. 2 for a simple two section, high-pass filter that will work well on most television receivers that are 150 feet or more from an amateur transmitter. For receivers that are closer than 150 feet, or that require more than average filtering, a more elaborate filter may be required. A four-section, high-pass filter that has worked successfully in a number of difficult situations is shown in

- C<sub>1</sub>, C<sub>2</sub>, C<sub>7</sub>, C<sub>8</sub> 50 $\mu$ f, Cornell-Dubilier Type 5W capacitors,  $\pm$  5% tolerance.
- C<sub>3</sub>, C<sub>4</sub> 20 $\mu$ f, Cornell-Dubilier Type 5W capacitors,  $\pm$  10% tolerance.
- C<sub>5</sub>, C<sub>6</sub>, C<sub>9</sub>, C<sub>10</sub> 15 $\mu$ f, Cornell-Dubilier Type 5W capacitors,  $\pm$  10% tolerance.
- L<sub>1</sub>, L<sub>2</sub>, L<sub>7</sub>, L<sub>8</sub> 0.62  $\mu$ h, 10 turns, close spaced, of #28 DCC wire, wound on the associated 50- $\mu$ f capacitor. (Type 5W cases are approx. 3/16"x7/16"x11/16".) The resonant frequency of each of these four LC units should be 29 Mc.
- L<sub>3</sub>, L<sub>4</sub> 1.6  $\mu$ h, 19 turns of #28 DCC wire on the associated 20- $\mu$ f capacitor. Adjust resonant frequency\* to 27 Mc.
- L<sub>5</sub>, L<sub>6</sub> 8.0  $\mu$ h, 23 turns of #28 DCC wire on a 3/4" diam. form. Adjust the resonant frequency of each coil with its associated 15- $\mu$ f shunt capacitor to 14.2 Mc\*.
- L<sub>A</sub> 1.05  $\mu$ h, 16 turns #28 DCC wire, coil length 1/2" on a 1/4" diam. form. Correct inductance\* may be obtained by adjusting turns to resonate at 15.6 Mc with an auxiliary 100- $\mu$ f capacitor.

\*For resonance specification requirements, see note under Fig. 2.

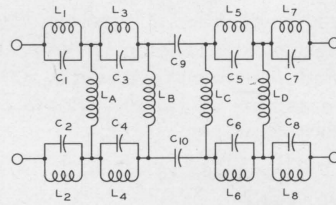

Fig. 3. Four-section, shunt-derived, high-pass filter for a 300-ohm line (Cutoff: 36.25 Mc).

- L<sub>B</sub> 0.79  $\mu$ h, 13 turns of #28 DCC wire, coil length 5/8" on a 1/4" diam. form. Adjust resonant frequency, using an auxiliary 100- $\mu$ f capacitor, to 18.3 Mc\*.
- L<sub>C</sub> 0.67 $\mu$ h, 12 turns #28 DCC, coil length 1/2" on 1/4" diam. form. Adjust resonant frequency, using auxiliary 100- $\mu$ f capacitor, to 19.2 Mc\*.
- L<sub>D</sub> 0.86 $\mu$ h, 16 turns #28 DCC, coil length 3/4" on a 1/4" diam. form. Adjust resonant frequency, using a 100- $\mu$ f auxiliary capacitor, to 17.1 Mc\*.

Fig. 3. Either of these filters can be built to exact specification with tools and equipment that are at the amateur's disposal. Reasonably good results may be obtained even if each resonant circuit is *not* set to the design frequency, providing the coils are wound as specified. The filters shown are good, practical devices and a "cook-book" method of constructing them may be all that is required to eliminate specific interference conditions. The two-section filter is shown in Fig. 1, and the four-section filter is shown in Fig. 4. Note how the components are arranged to minimize coupling between coils.

In order to understand the operation of these filters and the simplified design information on the construction of high-pass filters capable of satisfying any requirement, a review of the basic principles of high-pass filter design is of considerable value.

### Design Considerations

The following principles are involved in the selection of design parameters for high-pass filters:

1. The cutoff frequency of the filter should be as far as is practical from the pass-band frequencies.

2. The end sections of the filter should match the line. This match is obtained by utilizing the characteristic resistance of the line in the calculations, and by assuming a peak-attenuation frequency of 80 per cent of the design cutoff frequency.

3. The design cutoff frequency, once selected, should be used in the calculations for all sections of the filter.

4. The peak-attenuation frequencies of the intermediate sections should be selected to produce the greatest rejection for particular signals causing the most interference.

With these four principles in mind, let us select the design parameters. The cutoff frequency ( $f_{co}$ ) will fall between 30 and 55 Mc, preferably nearer 30 than 55. The center of amateur activity in the 30-Mc region is 29 Mc; consequently the maximum attenuation of the end sections is set most advantageously at 29 Mc. If the peak-attenuation frequency, 29 Mc, is to be 80 per cent of the

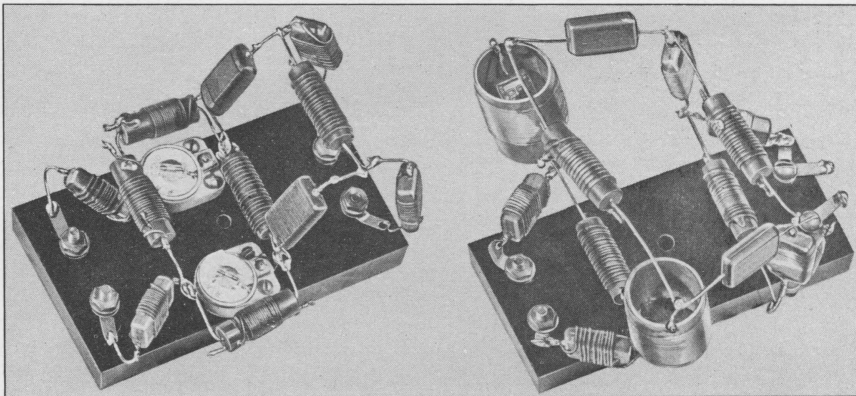

Fig. 4 On the left is shown a three-section, shunt-derived filter. The ceramic trimmers permit adjustment of the 27-Mc intermediate section after the filter has been installed in the TV set. The filter on the right is also a shunt-derived type, except that it has four sections. (Note that some of the coils are wound directly on the mica capacitors.)

cutoff frequency, then  $f_{co}$  should be 36.25 Mc. Because most television sets use 300-ohm Twin Lead for antenna feeders, 300 ohms will be used for "R" in the sample calculations that follow.

**Intermediate Sections**

The intermediate sections can provide additional attenuation for 10- or 11-meter signals, and they can also be designed to reject signals from the lower frequency amateur bands. With one intermediate section set for 27 Mc, one for 14.2 Mc, and a third section designed to build up good rejection characteristics in the 1.75, 3.5, and 7 Mc bands, protection against signals from the most populous amateur bands can be obtained. The third intermediate section, the one that rejects the low-frequency amateur signals, is designed by utilizing "0 Mc" as the peak-

attenuation frequency in the calculations.

The design parameters for the filter now can be listed in a table to assist in visualizing the arrangement. As a matter of fact, all of the important factors involved in the design of each section can be listed in tabular form. The first three lines of *Table I* show the items discussed thus far. These basic items must be used to determine the factors  $m$  and  $K$  which match the filter sections to each other and to the line.

**Matching Factors**

First of all,  $m$  is determined by the relation:

$$m = \sqrt{1 - \left(\frac{f_p}{f_{co}}\right)^2}$$

To save time, a curve (*Fig. 5*) has been

**Table I — Filter Design Factors**

	End Sections	Intermediate Sections			Units
Cutoff Freq. ( $f_{co}$ )	36.25	36.25	36.25	36.25	Mc
Peak-Attenuation Freq. ( $f_p$ )	29	27	0	14.2	Mc
Characteristic Res. (R)	300	300	300	300	ohms
$f_p/f_{co}$	—	0.745	0	0.392	—
$m$ (from <i>Fig. 5</i> )	—	0.67	1	0.92	—
$K$ (from <i>Fig. 6</i> )	—	0.205	0	0.041	—
$C_1$ Shunt-derived filter, <i>Fig. 8</i>	48.8	22	14.7	15.9	$\mu\mu f$
$L_1$ " " " " "	0.62	1.6	open circuit	8.0	$\mu h$
$L_2$ " " " " "	2.2	2.0	1.3	1.4	$\mu h$
$C_2$ Series-derived filter, <i>Fig. 7</i>	13.7	34.8	short circuit	176	$\mu\mu f$
$C_1$ " " " " "	48.8	43.8	29.3	31.8	$\mu\mu f$
$L_1$ " " " " "	2.2	1.0	0.66	0.72	$\mu h$

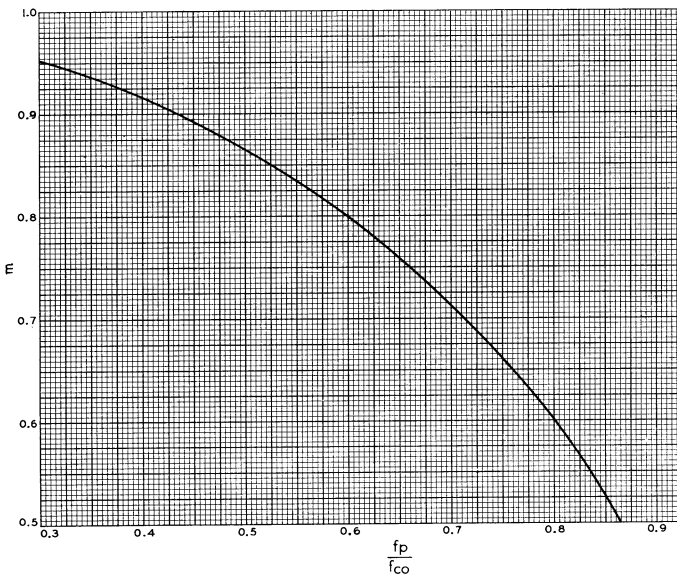

**Fig. 5.** The matching factor "m" for a high-pass filter section is obtained as follows: Divide the peak-attenuation frequency,  $f_p$ , of the section by the cutoff frequency,  $f_{co}$ . This quotient is then utilized to locate the value of "m" on this curve.

plotted which performs this operation. Simply read "m" opposite the value of  $f_p/f_c$  on the curve.

After "m" has been found, "K" can be calculated from:

$$K = \frac{1 - m^2}{4m}$$

Time can also be saved by taking the value of "m" previously determined, and using Fig. 6 to determine K.

When the matching factors, m and K, have been determined, all the items that are necessary for calculating inductance and capacitance values for any filter section are available. All that remains to be done is to take the numerical values of the items determined above, insert them in the appropriate formulas (given in Figs. 7 and 8), and perform operations of simple multiplication and division. The results will be values of capacitance and inductance for all components in each filter section.

#### Formulas for High-Pass Filters

The formulas used in these computations have been simplified from the equations in T. E. Shea's text book, "Transmission Networks and Wave Filters." All of the elements of the original equations have been retained in the simplified formulas presented here, so that a correct match to the television set, to the TV feeder, and between filter sections is maintained.

The circuits and the formulas for designing series-derived, m-type filters are given in Fig. 7, and the formulas for shunt-derived, m-type filters are given in Fig. 8. A high-pass

filter composed of series-derived sections requires fewer coils than a comparable filter composed of shunt-derived sections. To avoid complications, do not use both shunt-derived and series-derived sections in the same filter.

The amount of filtering required in a given installation determines the type of filter to be used and also the number of sections required. In outlying districts, a more effective high-pass filter may be required than would be needed for receivers nearer the TV station. Generally, receivers that are 150 feet or more away from the amateur transmitter can obtain sufficient rejection from a series-derived, two-section filter. For distances between 100 and 150 feet, two to four sections (series-derived) may be required. From experience with high-pass filters, at distances of less than 100 feet and with a transmitter running at 300-watts input, it has been found that three- or four-section shunt-derived filters are the most successful.

Perhaps, with shielding between sections and with the entire filter shielded, fewer sections would be required in the more elaborate units; however, it requires less time to build unshielded multiple-section filters than it does to build simple filters with shielding.

Component values for the two types of filters are listed in Table I. These values have been determined from the design formulas given in Figs. 7 and 8. Filters composed of one, two, or several sections can be designed from the data in Table I, and, in most cases, the only work required to design a good high-pass filter will be the selection of the appropriate component values

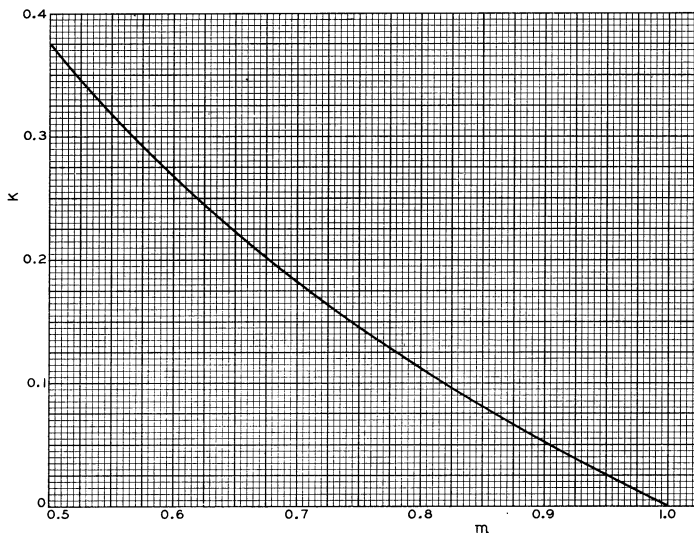
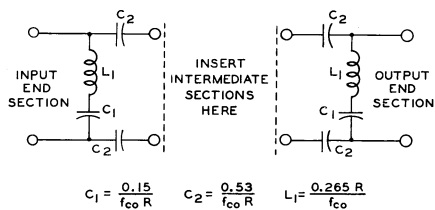
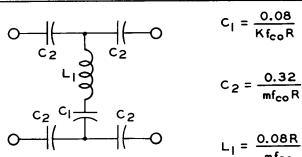

Fig. 6. After "m" is determined for a specific filter section, the corresponding value of "K" is obtained from this curve.



$$C_1 = \frac{0.15}{f_{co} R} \quad C_2 = \frac{0.53}{f_{co} R} \quad L_1 = \frac{0.265 R}{f_{co}}$$



$$C_1 = \frac{0.08}{K f_{co} R}$$

$$C_2 = \frac{0.32}{m f_{co} R}$$

$$L_1 = \frac{0.08 R}{m f_{co}}$$

INTERMEDIATE SECTIONS

Fig. 7. Circuits and design formulas for series-derived, m-type, high-pass filters. The end sections shown are actually half-sections. They match the line of characteristic resistance, "R", and have maximum attenuation at 80% of the cutoff frequency,  $f_{co}$ . The intermediate sections require factors "m" and "K" from Figs. 5 and 6. Units are: C, in

farads; L, in henries; frequency, in cps; and R, in ohms. The set of sample calculations which follows may serve as a guide since occasionally a filter may be required for a television receiver operating from a 72-

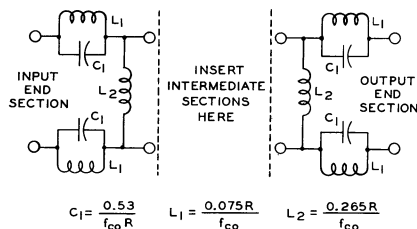

$$C_1 = \frac{0.53}{f_{co} R} \quad L_1 = \frac{0.075 R}{f_{co}} \quad L_2 = \frac{0.265 R}{f_{co}}$$

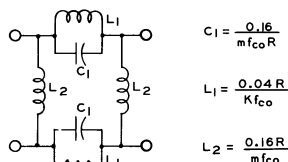

$$C_1 = \frac{0.16}{m f_{co} R}$$

$$L_1 = \frac{0.04 R}{K f_{co}}$$

$$L_2 = \frac{0.16 R}{m f_{co}}$$

INTERMEDIATE SECTIONS

ohm coax, or perhaps a cutoff frequency other than 36.25 Mc may be desired. In such cases, the new values of R and  $f_{co}$  should be used with the proper formulas. Shunt-derived filters have proved effective on TV receivers using 300-ohm feeders.

other than 36.25 Mc may be desired. In such cases, the new values of R and  $f_{co}$  should be used with the proper formulas.

### Sample Calculations

The following calculations are for a 300-ohm filter composed of shunt-derived, m-type sections:

End Sections (see Fig. 8)

$$R = 300, f_{co} = 36.25 \text{ Mc}$$

$$C_1 = \frac{0.53}{f_{co} R} = \frac{0.53}{36.25 (10^6) (300)}$$

$$= 48.8 \times 10^{-12} = 48.8 \mu\mu\text{f}$$

$$L_1 = \frac{0.075 R}{f_{co}} = \frac{0.075 (300)}{36.25 (10^6)}$$

$$= 0.62 \times 10^{-6} = 0.62 \mu\text{h}$$

$$L_2 = \frac{0.265 R}{f_{co}} = \frac{0.265 (300)}{36.25 (10^6)}$$

$$= 2.2 \times 10^{-6} = 2.2 \mu\text{h}$$

Intermediate Section (Fig. 8)

$$R = 300, f_{co} = 36.25 \text{ Mc}, f_p = 27 \text{ Mc}, \text{ where}$$

$$\frac{f_p}{f_{co}} = \frac{27}{36.25} = 0.745, m = 0.67 \text{ from Fig. 5.}$$

Since  $m = 0.67$ ,  $K = 0.205$  from Fig. 6.

$$C_1 = \frac{0.16}{m f_{co} R} = \frac{0.16}{0.67 (36.25) (10^6) (300)}$$

$$= 22 \times 10^{-12} = 22 \mu\mu\text{f}$$

$$L_1 = \frac{0.04 R}{K f_{co}} = \frac{0.04 (300)}{0.21 (36.25) (10^6)}$$

$$= 1.57 \times 10^{-6} = 1.6 \mu\text{h}$$

$$L_2 = \frac{0.16 R}{m f_{co}} = \frac{0.16 (300)}{0.67 (36.25) (10^6)}$$

$$= 1.98 \times 10^{-6} = 2.0 \mu\text{h}$$

Intermediate Section (Fig. 8)

$$R = 300, f_{co} = 36.25 \text{ Mc}, f_p = 0 \text{ Mc}^*, \text{ where}$$

$$\frac{f_p}{f_{co}} = \frac{0}{36.25} = 0, m = 1, \text{ and } K = 0$$

$$C_1 = \frac{0.16}{m f_{co} R} = \frac{0.16}{1 (36.25) (10^6) (300)}$$

$$= 14.7 \times 10^{-12} = 14.7 \mu\mu\text{f}$$

$$L_1 = \frac{0.04 R}{K f_{co}} = \frac{0.04 R}{0 f_{co}} = \infty$$

$\therefore L_1$  is equivalent to an open circuit.

$$L_2 = \frac{0.16 R}{m f_{co}} = \frac{0.16 (300)}{1 (36.25) (10^6)}$$

$$= 1.32 \times 10^{-6} = 1.3 \mu\text{h}$$

\*This section builds up the attenuation capabilities of the filter at low frequencies. It aids in the rejection of the 1.75, 3.5 and 7-Mc amateur bands.

An intermediate section for  $f_p = 14.2 \text{ Mc}$  could be calculated in the same manner as for the 27-Mc section. Other sections could be used instead of those for 14 and 27 Mc if the interfering signal occurs at some other frequency.

- C<sub>1</sub>, C<sub>2</sub>, C<sub>7</sub>, C<sub>8</sub> 50- $\mu\mu\text{f}$ , Cornell-Dubilier Type 5W capacitors;  $\pm 5\%$  tolerance.
- C<sub>3</sub>, C<sub>6</sub> 15  $\mu\mu\text{f}$ , Cornell-Dubilier Type 5W capacitors,  $\pm 10\%$  tolerance.
- C<sub>4</sub>, C<sub>5</sub> 4-30  $\mu\mu\text{f}$ , variable ceramic capacitor, Erie TS2A-N500.
- L<sub>1</sub>, L<sub>2</sub>, L<sub>7</sub>, L<sub>8</sub> 0.62  $\mu\text{h}$ , 10 turns #28 DCC wire close spaced, wound on the associated 50- $\mu\mu\text{f}$  capacitor. Adjust inductance to produce a resonant frequency of 29 Mc\* for each LC unit.
- L<sub>5</sub>, L<sub>6</sub> 8.0  $\mu\text{h}$ , 40 turns of #34 enamel wire close wound on associated 15- $\mu\mu\text{f}$  capacitor. Adjust inductance to produce a resonant frequency of 14.2 Mc\*.
- L<sub>3</sub>, L<sub>4</sub> 1.6  $\mu\text{h}$ , 17 turns of #28 DCC wire, coil length  $\frac{3}{8}$ " on  $\frac{1}{4}$ " diam. form. When the 4-30  $\mu\mu\text{f}$  shunt capacitor is set at maximum capacitance, the resonant frequency of the combination should be 23 Mc.
- L<sub>A</sub> 1.05  $\mu\text{h}$ , 16 turns #28 DCC, coil length  $\frac{1}{2}$ " on  $\frac{1}{4}$ " diam. form. Correct inductance\* may be obtained by adjusting turns to resonate at 15.6 Mc using an auxiliary 100- $\mu\mu\text{f}$  capacitor.
- L<sub>B</sub> 0.83  $\mu\text{h}$ , 17 turns #28 DCC, coil length  $\frac{7}{8}$ " on  $\frac{1}{4}$ " diam. form. Correct inductance\* may be obtained by adjusting turns to resonate at 17.4 Mc using an auxiliary 100- $\mu\mu\text{f}$  capacitor.
- L<sub>C</sub> 0.86  $\mu\text{h}$ , 16 turns #28 DCC, coil length  $\frac{3}{4}$ " on  $\frac{1}{4}$ " diam. form. Adjust to resonate at 17.1 Mc. using an auxiliary 100- $\mu\mu\text{f}$  capacitor.

\*For resonance specification requirements, see note under Fig. 2.

When the values for all of the components in the filters have been determined, the circuit may be diagrammed as shown in Fig. 9. The filter could actually be wired as indicated, but the circuit can be simplified by combining the inductance values which are in parallel. The basic operation is the same as that for determining the combined value of resistors in parallel. The combined value of inductances L<sub>x</sub> and L<sub>y</sub> in parallel is equal to

$$\frac{1}{L_x} + \frac{1}{L_y} = \frac{1}{L_{(total)}}$$

The four pairs of adjacent inductors in Fig. 9 are combined to complete the sample calculations:

Coil A:  $\frac{1}{2.2} + \frac{1}{2.0} = \frac{1}{L_A} = \frac{2.2 + 2.0}{(2.2)(2.0)}$   
 $\therefore L_A = 1.05 \mu\text{h}$

Coil B:  $\frac{1}{2.0} + \frac{1}{1.3} = \frac{1}{L_B} = \frac{2.0 + 1.3}{(2.0)(1.3)}$   
 $\therefore L_B = 0.79 \mu\text{h}$

Coil C:  $\frac{1}{1.3} + \frac{1}{1.4} = \frac{1}{L_C} = \frac{1.3 + 1.4}{(1.3)(1.4)}$   
 $\therefore L_C = 0.67 \mu\text{h}$

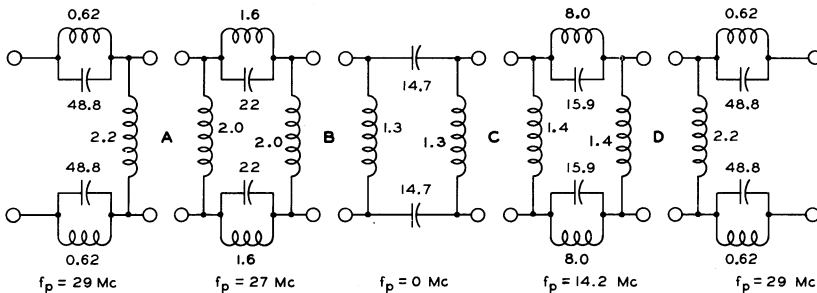

INDUCTANCE VALUES ARE IN  $\mu\text{h}$   
 CAPACITANCE VALUES ARE IN  $\mu\mu\text{f}$

Fig. 9. The four sections of the shunt-derived filter should be drawn in this manner before the adjacent inductances are combined. After the inductances are combined, the circuit is identical to that of the filter given in Fig. 3.

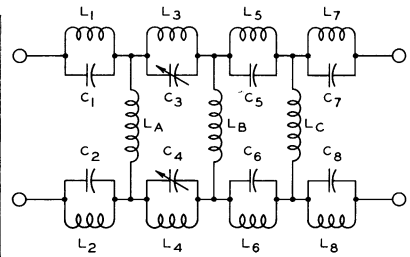

Fig. 10 Circuit diagram of a three-section, shunt-derived filter for 300-ohm TV feeder. The usable tuning range of the adjustable section is 25 to 30 Mc.

Coil D:  $\frac{1}{1.4} + \frac{1}{2.2} = \frac{1}{L_D} = \frac{1.4 + 2.2}{(1.4)(2.2)}$   
 $\therefore L_D = 0.86 \mu\text{h}$

**Mechanical Considerations**

The final circuit for the four-section, shunt-derived filter is the one shown in Fig. 3. The four section-coupling coils calculated above were made by winding No. 28 DCC wire on  $\frac{1}{4}$ -inch bakelite rods. The other coils were made by winding insulated wire around the capacitors as shown in the photograph of the completed filter. A higher Q is obtainable, however, if the coils are wound separately. As many of the coils as possible should be mounted at right angles to each other, and a reasonable physical separation should be kept between components to minimize coupling. The size of this filter is  $3\frac{1}{2}$ " x  $2\frac{1}{2}$ " x  $2\frac{1}{2}$ ".

It is sometimes helpful to have one section in a high-pass filter that can be tuned after it has been installed so that adjustment for maximum rejection of a particular interfering signal can be made. A three-section filter having a pair of tunable components for adjusting the maximum rejection point between 25 and 30 Mc is shown in Fig. 4. This

filter has shunt-derived, m-type sections; its circuit is shown in *Fig. 10*.

When a tuned section is incorporated in a series-derived filter, the tuned resonant circuit is located in a shunt arm.

### Series-Derived Filters

The arithmetic required for calculating component values for series-derived filters is similar to that shown in the shunt-derived example, the only difference being in the calculations needed for combining series capacitors. The formula

$$\frac{1}{C_x} + \frac{1}{C_y} = \frac{1}{C_{total}}$$

should be used if a minimum number of capacitors is to be employed.

The circuit for the two-section, series-derived, high-pass filter, *Fig. 2*, shows a tap at the center of the shunt coil. This tap is available for grounding the filter to the TV receiver chassis. Improved rejection has been obtained in some instances when a very short ground lead is run from this tap to the chassis. In many other installations, however, such a ground connection had no effect on the attenuation characteristic of the filter.

### Filters for TV Coax

Thus far, only filters for balanced lines have been discussed. Unbalanced feeders of the coax type theoretically should require an unbalanced filter, a configuration in which all of the series-reactive components are placed in the circuit of the center conductor. In some cases, in particular those in which the signal to be rejected is reasonably weak, the unbalanced type of filter is adequate. Sometimes, however, a strong amateur signal also produces a standing wave on the outside of the TV coax, and the rf field that

is present, in the region where the coax is connected to the receiver, couples energy to incompletely shielded components of the receiver. When this condition occurs, the outer conductor of the coax must be considered as a second wire, and it must therefore also be isolated from the receiver chassis by filter components. Such a filter would be a normal balanced line configuration, calculated for 72 ohms. A sketch of such an installation is shown in *Fig. 11*.

Where a TV coax shield is *not* coupling energy to the set components, an unbalanced-line filter is satisfactory. A small shield-can with coax fittings makes a good housing for an unbalanced line filter. The unit should be fastened to the TV chassis at a point where the "front-end" connection can be kept as short as possible.

### Converting Balanced to Unbalanced Structures

Designing unbalanced filters from the formulas given in *Figs. 7* and *8* is a simple matter. For 72-ohm coax, use 72 ohms for the value of "R" in the formulas and determine the values of all components, as in a balanced filter. The components that are connected across the transmission line in each section remain unchanged; the components in series with the transmission lines, however, must be lumped and placed in only one of the lines. The other line is a common ground to all sections of the filter. *Fig. 12* illustrates the conversion as applied to individual filter sections.

The conversion of a balanced filter to an unbalanced filter can also take place after the sections of a balanced filter have been combined. An example of this method of conversion is shown in *Fig. 13*. The component values given in this figure are practical,

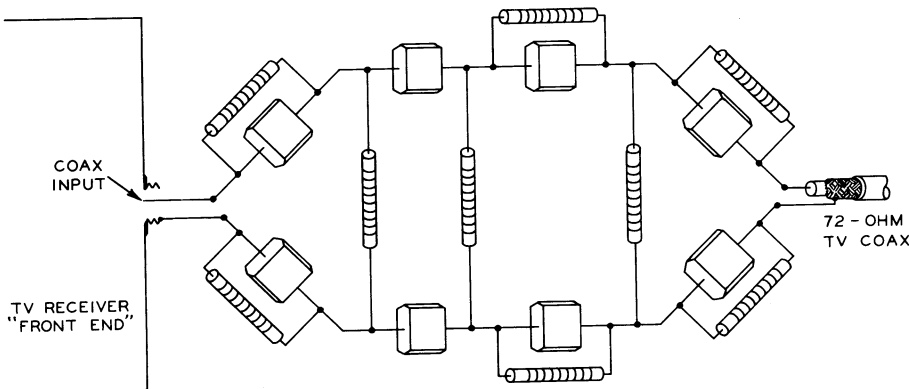

*Fig. 11.* Sketch showing how the inside and outside conductors of a coaxial transmission line are connected to a balanced 72-ohm, high-pass filter. This arrangement may be found necessary if an unbalanced-line filter is inadequate.



by other components in the filter section. The theoretical attenuation of each filter section at any given frequency can be calculated. Curves representing the attenuation characteristics of the individual sections listed in *Table I* are shown in *Fig. 15*.

When the attenuation is designated in decibels, it is easy to determine the combined effect of two or more sections of a filter because the attenuation values, at a given frequency can be added numerically. The sum of the values for all sections is the attenuation, at the given frequency, of the entire filter. The theoretical attenuation curves for three specific filters are shown in *Fig. 16*. When the attenuation in a given filter is estimated, keep in mind that for each 6 db of attenuation the voltage is cut in half. For instance, 24-db attenuation of a 1-volt signal would be equivalent to four progressive reductions of 50 per cent (0.5, 0.25, 0.125, and 0.0625), producing an output of 0.0625 volt.

If a particular receiver evidences interference when a 1-volt signal is introduced at the input to the tuner, some attenuation of that signal is required. Perhaps a filter capable of an attenuation of 24 db is adequate. Then, with such a filter, interference rejection would be satisfactory unless a 16-volt signal happened to be introduced. Sixteen volts is 24 db above one volt, so a 48-db

filter would be required to provide adequate rejection of the stronger signal.

Sixteen volts may seem like a lot of rf to be available on a TV antenna, but voltages of this order of magnitude are not unusual when an amateur transmitter and a television receiver are within 15 or 20 feet of each other. As a matter of fact, a number of cases have been reported in which a neon bulb could be lighted at the TV receiver terminals when the amateur transmitter was on the air. Neon bulbs do not glow unless the potential applied is approximately 50 volts or higher.

Because television-antenna transmission lines do not match the antenna and the receiver at low frequencies, standing waves from the amateur signal are present on the line. A voltage-maximum point occasionally occurs at the receiver terminals, and when this condition exists, changing the length of the TV feeder may shift the location of the voltage maximum and reduce the rf at the receiver terminals. Adjustments of this type are helpful in minimizing the burden placed on a high-pass filter.

### Other Paths for Interfering Signals

The installation of a booster also changes the effective length of a transmission line. Furthermore, after a booster has been installed, it may be found that there is an

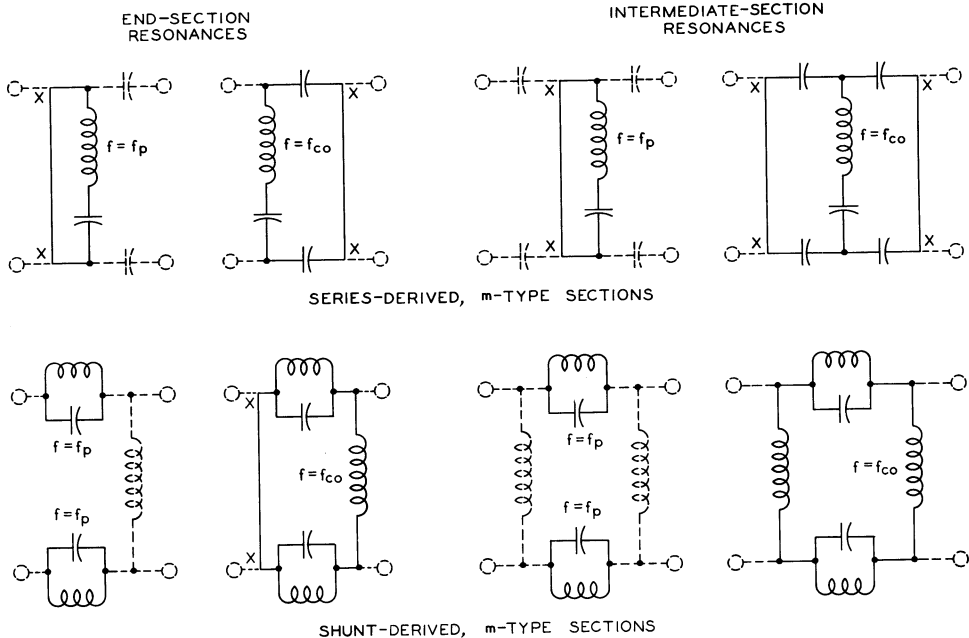

Fig. 14. The resonant circuits designated by solid lines are the combinations utilized to check the filter design calculations. Although not actually connected in a filter, lines x-x are shown to complete the resonant circuit when it is checked mathematically.

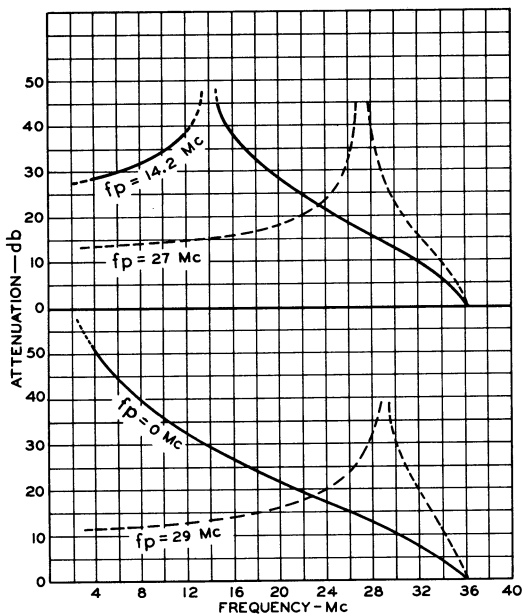

Fig. 15. These curves show the theoretical attenuation for individual sections of high-pass filters. The combined effect of the two end-sections is given in the 29-Mc curve. The other three curves are for intermediate sections. All of these sections were designed for a cutoff frequency of 36.25

increase in interference due to the addition of one or more paths along which the amateur signal can enter the television receiver. Preventing an amateur fundamental from entering a booster is just as important as preventing the signal from entering a TV receiver, so a high-pass filter at the booster input is required. Sometimes a second high-pass filter is required between the booster and the receiver because the transmission line between the two units can pick up a strong amateur signal. The power-supply cord to the booster may also be involved in the transfer of an amateur fundamental to the TV receiver.

### Supply-Line Filters

In some installations, the line cord to the TV receiver has been found to be a path along which the amateur signal enters the receiver. The amateur signal can get into the power line either by being fed directly into the ac line at the transmitter, if the rf filters in the power supply are inadequate, or by being picked up by the house wiring at the TV receiver location. The house wiring, including BX cable, may be a very effective receiving antenna.

Water, gas, and steam pipes are also capable of acting like receiving antennas. A "ground" wire connected from a TV receiver

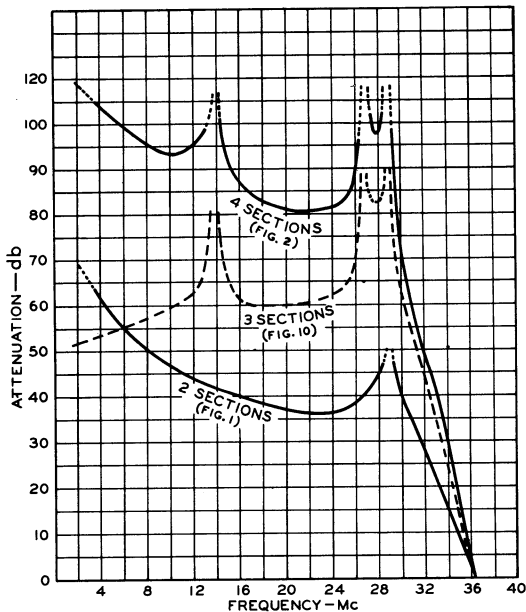

Fig. 16. Theoretical attenuation of several of the filters discussed in this article. In actual practice, these filters have been effective in rejecting amateur signals, and there has been no evidence of attenuation in the TV pass bands.

to a radiator may couple an amateur signal to the exposed components of a TV chassis. Direct pick-up by long leads in phonograph-radio TV consoles have also been found capable of introducing unwanted signals.

All long leads—line cords, speaker cables, etc. are capable of introducing a strong amateur signal to the vulnerable sections of a television receiver. RF chokes, placed in series with the leads, help in rejecting the undesired signals. A bypass capacitor connected at the point where the lead enters the chassis adds to the effectiveness of the choke in eliminating the interfering signal.

### Conclusion

There are many variables involved in reducing interference in a television receiver. Each installation where interference is encountered may be slightly different from all the others. Fortunately, however, high-pass filters *will* solve almost all of the amateur interference problems attributable to receiver difficulties, and intelligent application of these devices should reduce to a minimum the number of unhappy situations that exist in the radio amateur's neighborhood.

#### INTERESTED IN TVI ARTICLES?

The next issue of HAM TIPS will contain a complete bibliography of TVI articles — a handy time-saving list. Don't miss it!

# BEAM POWER



**PICK YOUR POWER FROM THIS CHART**

Final Amplifier	Beam Power	R.F. Driver	Molecular Tube
Watts Input	Beam Power	Tube Type	Push-Pull Stage
CW 100% Phone	1.5	5763	5A6S
54	30	PP 5763	6E6
40	27	2E26	AB <sub>1</sub>
80	54	PP 2E26	2E26
75	60	807	807
150	120	PP 807	807
500	400	PP 813	811-A
1000	800	PP B13	810
Maximum V <sub>pk</sub> Ratings for RF Amplifier—Class C Telegraphy			B
Maximum V <sub>pk</sub> Ratings for AF Amplifier—Class C Telegraphy			

The Fountainhead of Modern Tube Development is RCA

## In modern rigs power gain counts ...and RCA Beam Power tubes have it

THIS QUARTET of beam power tubes offers the modern approach to compact, efficient transmitter design. They require less drive and deliver more output at lower plate voltage, than any other similar tube types within a comparable price range. In addition . . . the absence of high-level intermediate stages in a beam power transmitter is a long step toward the elimination of TVI.

What's more . . . these RCA beam power tubes are excellent for quick-change, multi-band transmitters because they seldom require stabilization in well-designed circuits.

Newest of the family is the RCA-5763 miniature . . . capable of 17 watts input (ICAS-class C telegraphy) to 175 Mc. Its high power gain and *extra* emission make it a highly efficient frequency multiplier.

To get all the performance and life *you* pay for . . . buy genuine RCA tubes in the familiar red, black, and white cartons from your local RCA tube supplier.

Are you getting the new RCA HAM TIPS? Copies are available from your local RCA tube supplier.



**RADIO CORPORATION of AMERICA**  
ELECTRON TUBES

HARRISON, N. J.



From your local RCA distributor, headquarters for RCA receiving and power tubes.

RCA HAM TIPS is published by the RCA Tube Dept., Harrison, N. J. It is available free of charge from RCA Distributors

Lawrence LeKashman,  
Editor W210P

Joseph Pastor, Jr.,  
Assoc. Editor W2KCN

If undeliverable for any reason, notify sender, stating reason, on Form 3547, postage for which is guaranteed.

WHEN MAILING  
PLACE POSTAGE HERE

